



Product Specification

Ningbo East Electronics Limited
NO. 88 East Jinhui Road, Yinzhou Ningbo 315100, P.R.China
<http://www.east-mingtao.com>

Product Name:	High-Output Alarm Annunciator
Part Number:	EFM-290EDFWL100
Version:	1.04
Date:	2016-3-8
Note:	UTC P/N: 0000-3038

Company passed ISO 9001 / ISO TS16949 / ISO 14001 Certifications

Revision History

Rev.	Description	Author/Date	Checked By	Approver
1.04	Change the Packing Information.	俞凯 2016-3-8	汤礼东	王建成
1.03	Quality Certificate Symbol revised	吕文斌 2015-2-6	汤礼东	王建成
1.02	Add the Silver Electrode Thickness	吴磊 2013-5-7	张春雷	王建成

1. Part Number EFM-290EDFWL100

2. Dimension Drawing (Unit: mm)

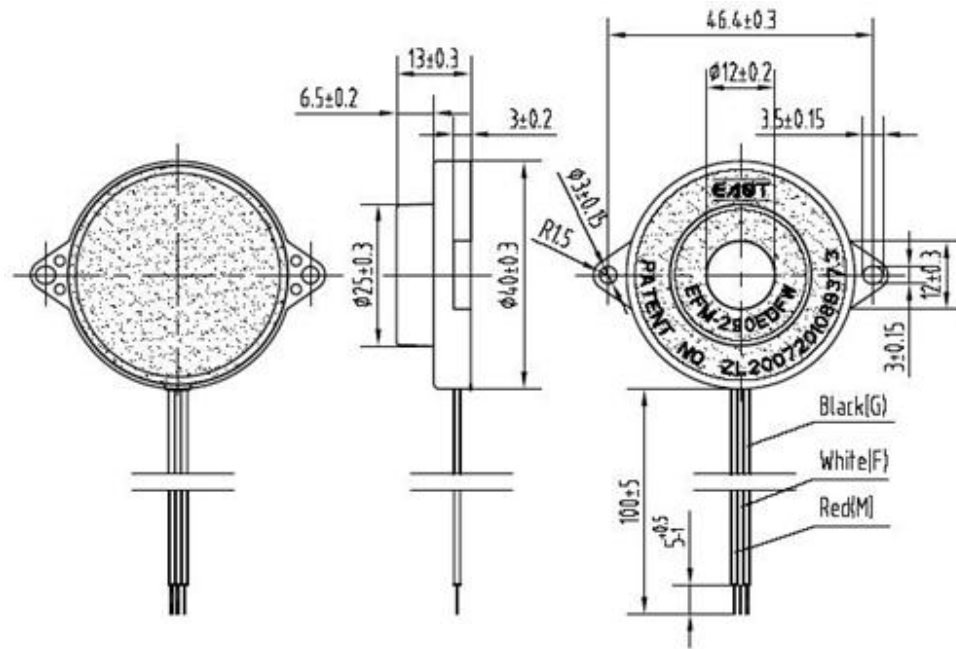

3. Specification

No.	Item	Specification
3-1	Min. Sound Pressure Level	85dB/9V _{DC} /300cm
3-2	Rate Voltage	9V _{DC}
3-3	Operating Voltage	6~12V _{DC}
3-4	Max. Consumption	30mA/9V _{DC}
3-5	Oscillating Frequency	3.2± 0.5kHz
3-6	Operating Temperature	-20~+70°C
3-7	Storage Temperature	-20~+85°C
3-8	Case Material /Color	PC (141R)/Black
3-9	Weight	8.9g
3-10	Wire Standard	UL1095-28AWG
3-11	Silver Electrode Thickness	5±2um

NOTE:

Test should be made under the conditions of room temperature (20±10°C), normal humidity (60±20%) and normal atmospheric pressure. In this case, however, that the judgment is questionable, the test conditions are to be changed to room temperature 20±2°C, relative humidity 60~70% and normal atmospheric pressure.

4. Typical Frequency Response Curve

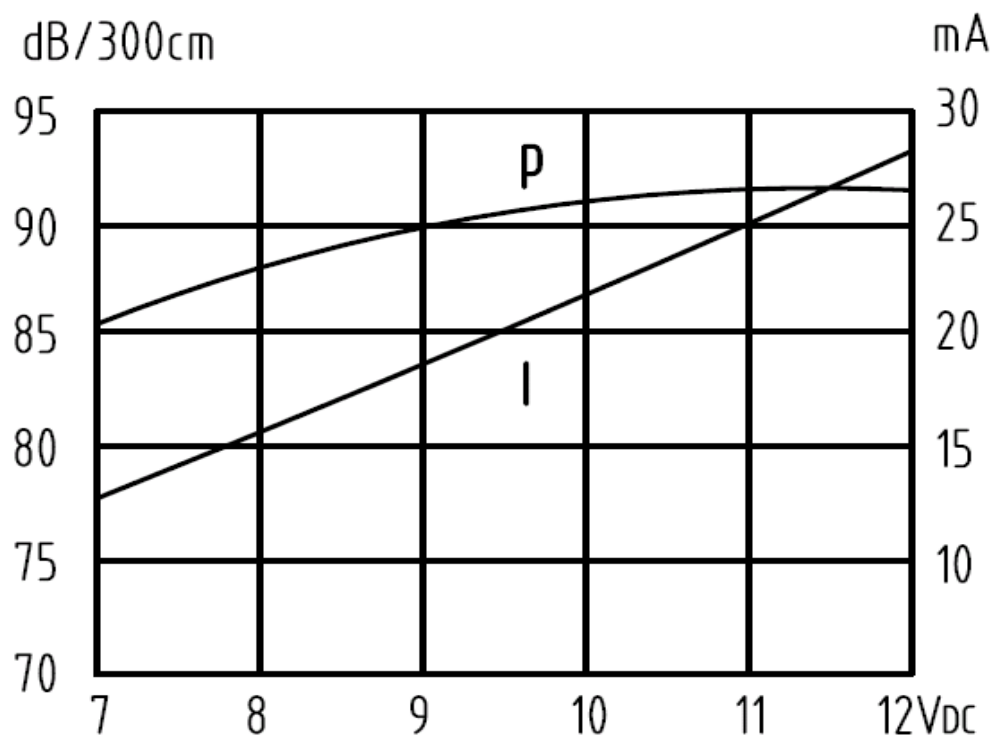

Note: Distance 300 cm

5. Electrical Testing Method

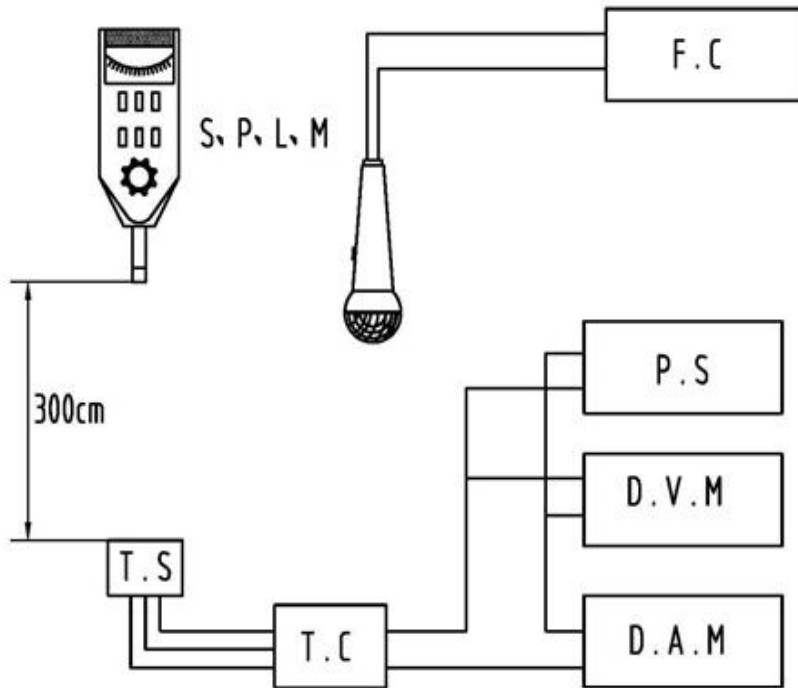

S.P.L.M	Sound Pressure Level Meter
T.S	Testing Sample
T.C	Test Circuit
F.C	Frequency Counter
P.S	Power Supply
D.V.M	DC Voltage Meter
D.A.M	DC Ampere Meter

T.C:

Offered By Client

6. Packing Information

Packing: 1190 pcs per export carton

Carton Size: 47× 30.5× 23 cm

G. Weight: 13.3 kgs N. Weight: 10.6 kgs